



*A proven history of performance and durability*

# Vortec 3000

## Industrial Engine

### Features & Benefits

#### **MPFI Version (LMX):**

- Multi-port electronic fuel injection (MPFI) version that uses gasoline only
- Capable of meeting current and future emissions regulations
- Cylinder head targets fuel injectors to back of intake valves for quick response to changing conditions
- Stainless steel MPFI fuel rail resists corrosion

#### **Gaseous Version (LW6):**

- Customized for gaseous fuels only, taking advantage of the higher octane levels by using a higher compression ratio

#### **All Versions:**

- Sintered powder metal exhaust valve seat inserts for enhanced durability
- High Energy Ignition (HEI) distributor and coil are standard
- Nodular iron crankshaft for increased strength and durability



*The 8-port cylinder head configuration of the Vortec 3000 engine has a MPFI version and a gaseous-fuel-only version.*

### Available Options

- An electronic control module (ECM) for optimizing fuel and spark requirements is available in kit form (gasoline only).
- Available in low and high compression ratio.

# Vortec 3000 Industrial Engine

## Vortec 3000 Feature Focus

The Vortec 3000 is currently used exclusively in marine and industrial applications. Whether on the water or on the job, the Vortec 3000 delivers the durable power you need.



*All GM industrial engines are Vortec engines. Vortec means uncompromised power — outstanding power with no sacrifice in fuel efficiency or durability and very little required maintenance.*



*The 8-port version of the cylinder head is used for the MPFI gasoline version and the gaseous-fuel-only version of the Vortec 3000. The gaseous-fuel-only version has a camshaft profiled to take advantage of the higher octane in propane and natural gas.*

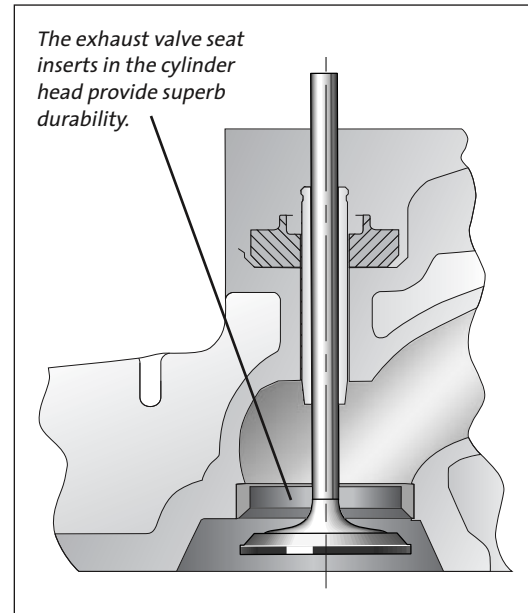

*The Vortec 3000 Engine, with the longest history of any industrial engine offered by GM Powertrain, has a well-earned reputation for durability and reliability.*

## Specifications

**Type:** 3.0L I4

**Displacement:** 181 cid (2966.59 cc)

**Engine Orientation:** Longitudinal

**Compression Ratio:** 10.5:1 (LW6), 9.2:1 (LMX, High CR)  
8.25:1 (LMX, Low CR)

**Valve Configuration:** Pushrod Actuated  
Overhead Valves  
(2 valves per cylinder)

**Assembly Site:** Toluca, Mexico

**Valve Lifters:** Hydraulic Flat Tappet

**Firing Order:** 1 - 3 - 4 - 2

**Bore x Stroke:** 101.60 x 91.44 mm

**Bore Center:** 112.26 mm

**Bore Area:** 324.29 cm<sup>2</sup>

**Fuel System:** MPFI Fuel Rail and Injectors (LMX)  
N/A (LW6)

**Fuel Type:** LMX: Gasoline (MPFI)  
LW6: Propane, Natural Gas

**Horsepower:**

94 hp (70 kW) @ 3200 rpm (MPFI: Gasoline (LMX))  
Low CR

93 hp (69 kW) @ 3000 rpm (MPFI: Gasoline (LMX))  
High CR

73 hp (54 kW) @ 2200 rpm (Natural Gas: (LW6))

64 hp (48 kW) @ 1800 rpm (Propane: (LW6))

**Torque:**

188 lb-ft (255 Nm) @ 1800 rpm (Propane: (LW6))

178 lb-ft (241 Nm) @ 1600 rpm (Nat. Gas: (LW6))

172 lb-ft (233 Nm) @ 1800 rpm (MPFI: Gasoline (LMX))  
High CR

168 lb-ft (228 Nm) @ 2300 rpm (MPFI: Gasoline (LMX))  
Low CR

**Fuel Shutoff:** OEM defined

**Shipping Weight:** 363 lb (165 kg)

**Materials:**

Block: Cast Iron

Cylinder Head: Cast Iron with exhaust valve seat inserts

Intake Manifold: Customer Supplied

Exhaust Manifold: Customer Supplied

Main Bearing Caps: 2 -Bolt Cast Iron

Crankshaft: Nodular Cast Iron

Camshaft: Indus. Profile Low Speed, High Torque (8-port)

Industrial Gaseous Fuel Profile (8-port)

Connecting Rods: Powdered Metal

Information may vary with application. All specifications listed are based on the latest product information available at the time of publication. The right is reserved to make changes at any time without notice.



**GM Powertrain**

[www.gmpowertrain.com](http://www.gmpowertrain.com)

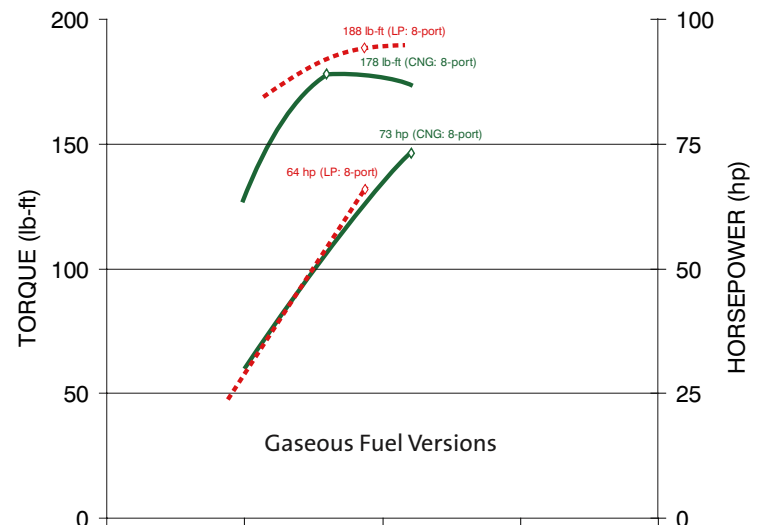
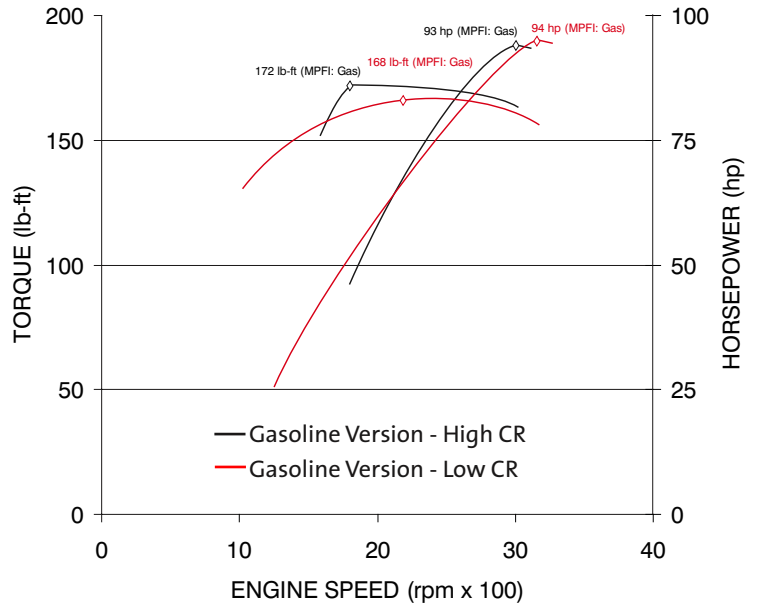

Actual power levels may vary depending on OEM calibration and application.

