



A very efficient engine that offers proven performance in a compact package. It is a global engine used in a multitude of applications.

Vortec 1600

Industrial Engine

Features & Benefits

- Designed to use gasoline, propane, and natural gas
- Hardened valve seat inserts to maintain excellent performance when using alternative fuels
- Single overhead cam valvetrain optimizes performance and efficiency
- Crank-triggered, waste spark ignition system utilizes the coil pack, crankshaft position sensor and available ECM for accurate spark timing
- World-class engine sealing system for superior leak protection
- Poly-V belt harmonic balancer is standard
- Aluminum PFI-style intake manifold can be used for gaseous fuels (LPG or Natural Gas) or can be up-fitted with the optional gasoline fuel system
- Pistons have high silicon content for improved durability and noise reduction
- Exhaust manifold heat shield reduces radiated heat to nearby components
- Engine has a badge area on top where OEMs can place their own identifying badge



The Vortec 1600 engine from GM's Sao Jose engine plant in Brazil is the smallest displacement engine that GM Powertrain provides for OEM applications.

Available Options

- An electronic control module (ECM) for optimizing fuel and spark requirements is available in kit form (gasoline only).
- Gasoline fuel rail for port fuel injection that precisely meters fuel
- Intake manifold pressure/temperature sensor (intake or remote mount)
- Flat response knock sensor

Vortec 1600 Feature Focus

The Vortec 1600 is a global engine used in a multitude of applications. It has a reputation around the world for delivering the uncompromised power and rugged durability you've come to expect from GM Vortec engines.



All GM industrial engines are Vortec engines. Vortec means uncompromised power — outstanding power with no sacrifice in fuel efficiency or durability and very little required maintenance.

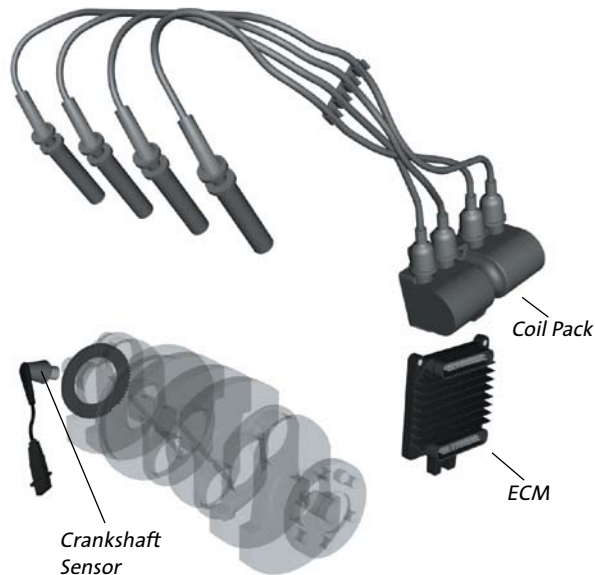

The crank-triggered, waste spark ignition system uses a crankshaft position sensor, coil pack, and available ECM to replace the distributor and coil used in conventional ignition systems, so servicing of distributor caps and rotors is eliminated. Crankshaft position is precisely determined directly from the crankshaft, resulting in improved spark accuracy. The OEM-established spark timing cannot be changed by the end user.

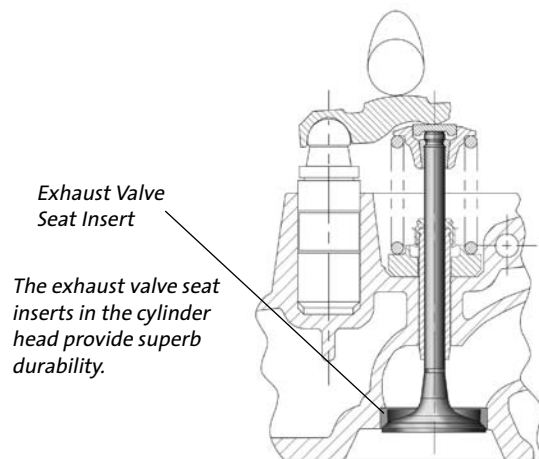

Exhaust Valve Seat Insert
The exhaust valve seat inserts in the cylinder head provide superb durability.



OEM Badge Area
The Vortec 1600 engine has a badge area on top where OEMs can place their own identifying badge.



This Vortec 1600 is shown with optional gasoline port fuel injection system and manifold pressure/temperature sensor.

Specifications

Type: 1.6L I-4

Displacement: 98 cid (1,598 cc)

Engine Orientation: Longitudinal and Transverse

Compression Ratio: 9.4:1

Valve Configuration: Single Overhead Camshaft
(2 valves per cylinder)

Assembly Site: Sao Jose dos Campos, Brazil

Valve Lifters: End pivot finger follower
w/lash adjuster

Firing Order: 1-3-4-2

Bore x Stroke: 3.11 x 3.20 in. (79.0 x 81.5 mm)

Bore Center: 86 mm

Bore Area: 196.07 cm²

Fuel System: None - gasoline fuel rail optional

Fuel Type: Gasoline, Propane, Natural Gas

Horsepower:

100 hp (75 kW) @ 6000 rpm (Gasoline)

66 hp (49 kW) @ 4000 rpm (Propane)

58 hp (43 kW) @ 4000 rpm (Natural Gas)

Torque:

103 lb-ft (140 Nm) @ 3200 rpm (Gasoline)

90 lb-ft (122 Nm) @ 2800 rpm (Propane)

81 lb-ft (110 Nm) @ 3000 rpm (Natural Gas)

Actual power levels may vary depending on OEM calibration and application.

Fuel Shutoff: OEM Defined

Shipping Weight: 220 lb (100 kg)

Engine Redline: 6500 rpm

Emissions Controls: OEM Defined

Applications: Industrial Applications
(Generators, Sweepers, Aerial Lifts, etc.)

Materials:

Block: Grey Cast Iron

Cylinder Head: Aluminum with Valve Seat Inserts

Intake Manifold: PFI style (Alum.) w/o TB

Exhaust Manifold: Cast iron

Main Bearing Caps: 2-Bolt

Crankshaft: Nodular Iron

Camshaft: Cast Iron

Connecting rods: Cast Iron

Information may vary with application. All specifications listed are based on the latest product information available at the time of publication. The right is reserved to make changes at any time without notice.

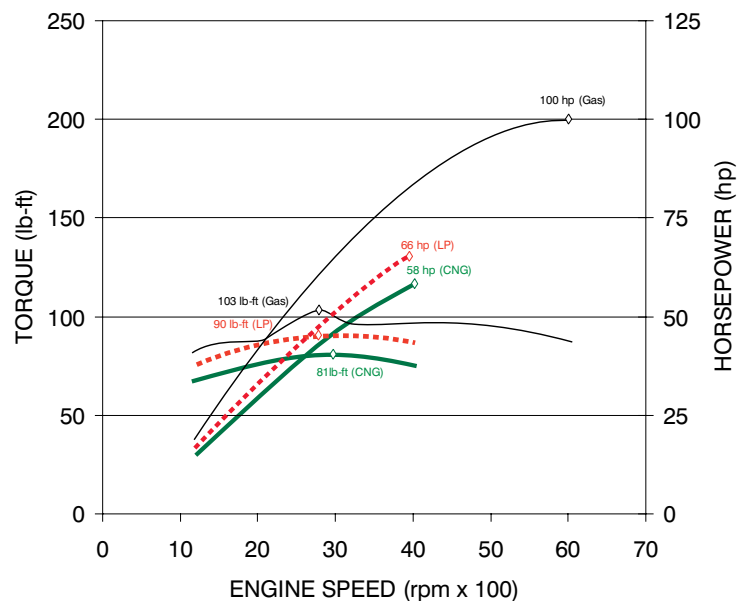

Actual power levels may vary depending on OEM calibration and application.

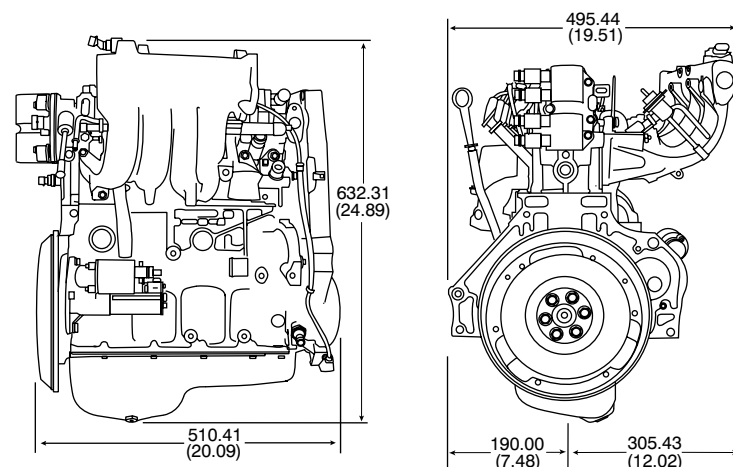

GM Powertrain

www.gmpowertrain.com